

圓頭十字螺絲



型號 SPHPCM()-L

PC 聚碳酸酯(Polycarbonate) / 工程塑膠

PC是由雙羥基化合物中之丙二酚(bisphenol-A)、碳酸鹽化合物中之碳酸二苯酯(diphenylcarbonate)由酯交換法(熔融法)反應所聚合而成的聚碳酸酯樹脂。聚碳酸酯樹脂具有優異透明性、高耐熱性、超高耐衝擊性、尺寸安定性...等等，使其適用的範圍相當的廣泛。是一種可供多樣化選擇之材料。

特性

1. 良好的加工成型性
2. 衝擊強度高
3. 具有阻燃性以及抗紫外線
4. 尺寸安定性佳，良好的透光率
5. 備有FDA認可之型號

適用產業



規格

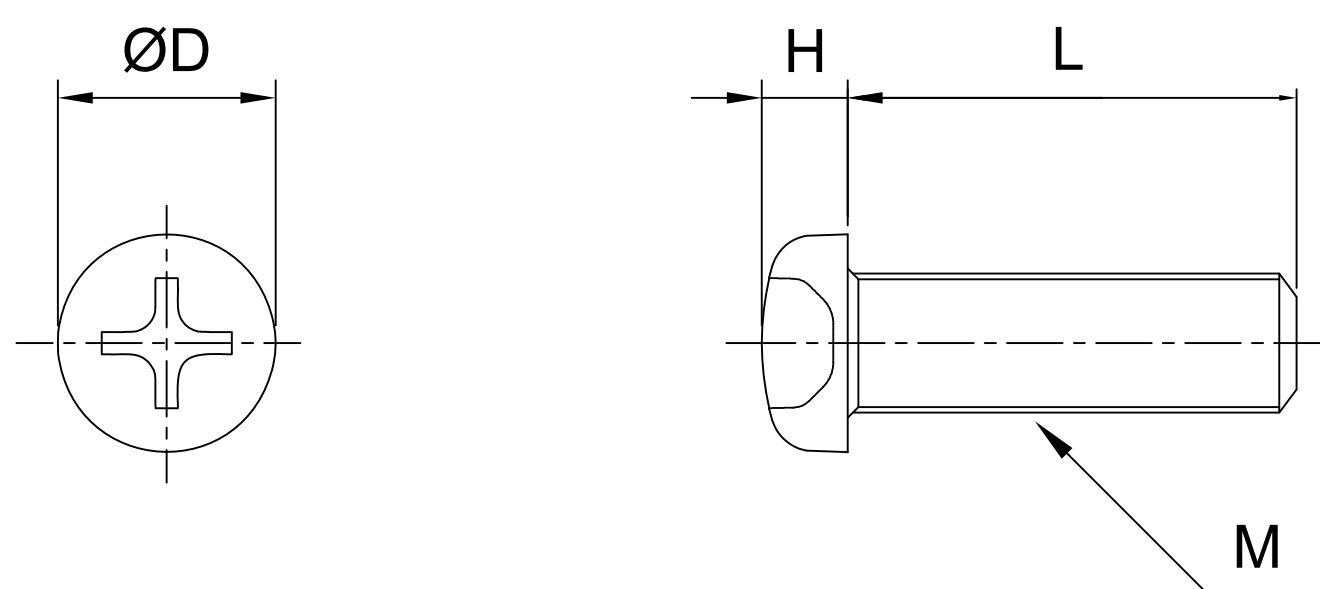

型號: SPHPCM()-L

M	2	3	4	5	6	8
DxH	3.5x1.3	5.5x2	7x2.6	9x3.3	10.5x3.9	14x5.2
Pitch	0.4	0.5	0.7	0.8	1	1.25
L(mm)	4	●	●	-	-	-
	5	●	●	●	-	-
	6	●	●	●	●	-
	8	●	●	●	●	-
	10	●	●	●	●	●
	12	●	●	●	●	●
	15	-	●	●	●	●
	16	-	●	●	●	●
	20	-	●	●	●	●
	25	-	●	●	●	●
	30	-	-	●	●	●
	35	-	-	●	●	●
40	-	-	●	●	●	
45	-	-	-	-	●	
50	-	-	-	-	●	

聯絡資訊

505008彰化縣鹿港鎮東崎里東崎七巷60-3號
E-mail: sales@plasautotw.com

TEL: +886-4-778-4688
FAX: +886-4-778-4268

